



Portapunzone True-Fit

Insertable punch retainers True-Fit



MRI

Versione integrale

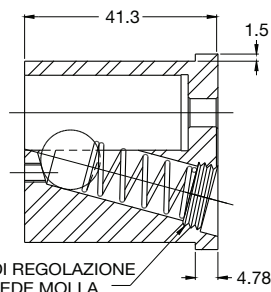
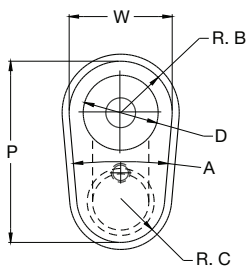

MRJ

Versione con piastra di ritegno

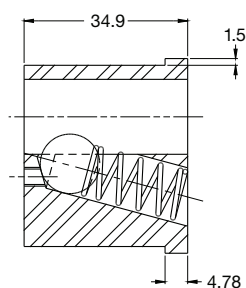
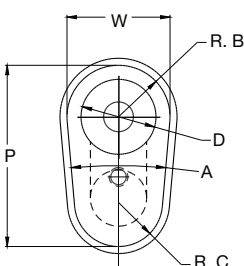

CODICE	D	P	W	A	R. B	R. C
MR_010	10	29.48	15.88	5°	7.94	7.32
MR_013	13	36.04	19.05	5°	9.53	8.75
MR_016	16	39.21	22.23	10°	11.11	9.49
MR_020	20	42.39	25.4	10°	12.70	11.08
MR_025	25	48.74	31.75	30°	15.88	9.94
MR_032	32	55.09	38.10	30°	19.05	13.12
MR_040	40	63.69	48.00	30°	24.00	18.52

Dimensioni per foro inserimento True-Fit

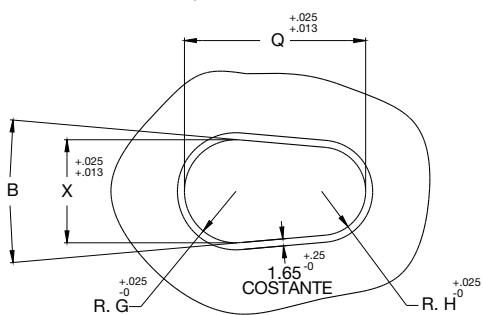

Ø PUNZONE	Q	X	B	R. G	R. H
10	29.494	15.885	5°	7.943	7.323
13	36.048	19.060	5°	9.530	8.755
16	39.223	22.235	10°	11.118	9.497
20	42.398	25.410	10°	12.705	11.085
25	48.748	31.760	30°	15.880	9.949
32	55.098	38.110	30°	19.055	13.124
40	63.699	48.010	30°	24.005	18.526

MRI

Versione integrale

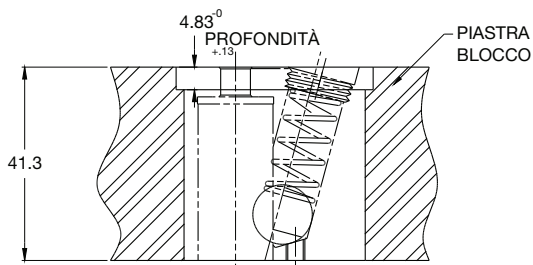

MRJ

Versione con piastra di ritegno

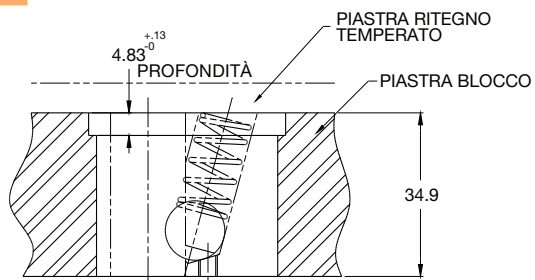

Esempio di ordinazione/Order example: MRI010 (codice)