

Colonna con collare estraibile

Guide post demountable

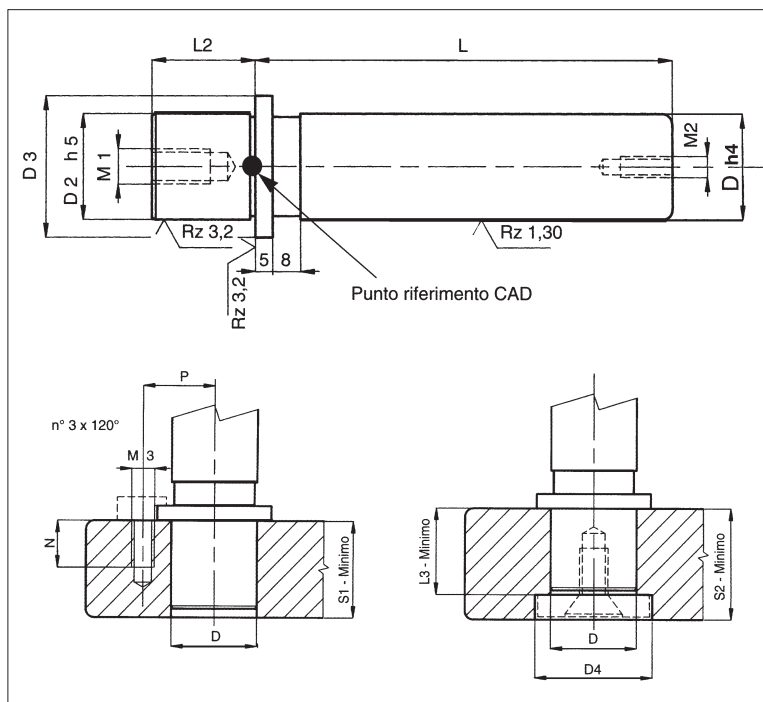
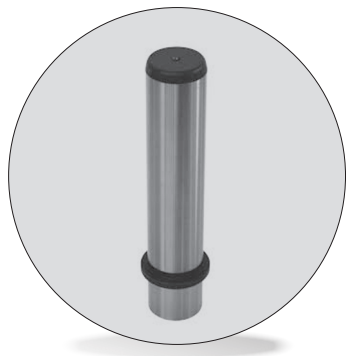

Ogni colonna è corredata di n°3 staffette con viti oppure a richiesta: n°1 rondella RT con vite (vedere pag. 5.30).

Codice	Materiale	Trattamento	HRC
Cod. CF 419	1.7131	cmt - tmp	61- 63

D	D2	D3	D4	L2	L3	M1	M3	N	P	S1	S2	Sede mont JS 6	
18	18	25	27	20	21	8 x 1,25	6 x 1	12	16	23	28	18	± 0,006
19	19											19	
24	24	32	34	25	26	10 x 1,5	8 x 1,25	16	19,5	28	33	24	± 0,006
25	25											25	
30	30	40	42	30	31	12 x 1,75	8 x 1,25	16	25	33	38	30	± 0,006
32	32											32	
40	40	50	52	35	36	12 x 1,75	8 x 1,25	16	30	38	48	40	± 0,008
42	42											42	
50	50	62	64	45	46	12 x 1,75	8 x 1,25	16	36	48	58	50	± 0,008
52	52											52	
63	63	73	75	49	50				41,5	53	63	63	± 0,010
*80	80	93	95	59	60				51,5	63	73	80	

M2 = Filetto anteriore M10 solo su ø 80

* ø 80 solo su richiesta. ø 80 only on request.

D	L																		
		100	110	120	130	140	150	160	170	180	200	220	240	260	280	300	320	360	400
18-19		•	•	•	•	•	•	•											
24-25		•	•	•	•	•	•	•	•	•									
30-32		•	•	•	•	•	•	•	•	•	•	•	•	•					
40-42		•	•	•	•	•	•	•	•	•	•	•	•	•	•	•	•		
50-52			•	•	•	•	•	•	•	•	•	•	•	•	•	•	•	•	•
63					•	•	•	•	•	•	•	•	•	•	•	•	•	•	•
*80									•	•	•	•	•	•	•	•	•	•	•

Esempio di ordinazione/Order example = CF419 - 18x140 (cod. + D + L)