

# Piastra di scorrimento autolubrificante VDI 3357

Wear plate self-lubricating VDI 3357

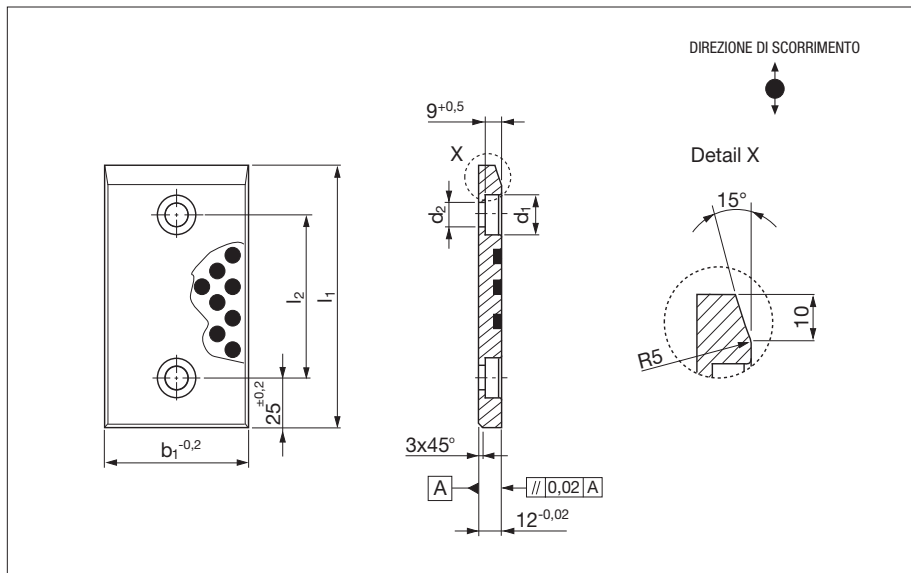
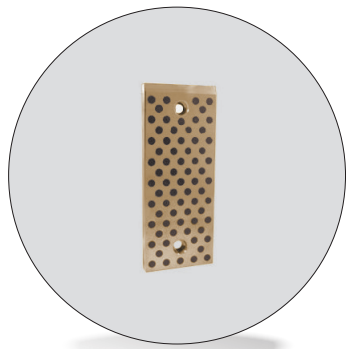

Codice	Cod. <b>A608</b>
Materiale	Bronzo + grafite HB $\geq$ 190

Code	b1	d1 H13	d2 H13	l1 $\pm 0,2$	l2 $\pm 0,2$
A608-11-030-080	30	15	9	80	30
A608-12-030-100	30	15	9	100	50
A608-13-030-125	30	15	9	125	75
A608-14-030-160	30	15	9	160	110
A608-15-030-200	30	15	9	200	150
A608-16-040-080	40	15	9	80	30
A608-17-040-100	40	15	9	100	50
A608-18-040-125	40	15	9	125	75
A608-19-040-160	40	15	9	160	110
A608-20-040-200	40	15	9	200	150
A608-21-050-080	50	15	9	80	30
A608-22-050-100	50	15	9	100	50
A608-23-050-125	50	15	9	125	75
A608-24-050-160	50	15	9	160	110
A608-25-050-200	50	15	9	200	150
A608-26-060-080	60	15	9	80	30
A608-27-060-100	60	15	9	100	50
A608-28-060-125	60	15	9	125	75
A608-29-060-160	60	15	9	160	110
A608-30-060-200	60	15	9	200	150
A608-31-080-080	80	15	9	80	30
A608-32-080-100	80	15	9	100	50
A608-33-080-125	80	15	9	125	75
A608-34-080-160	80	15	9	160	110
A608-35-080-200	80	15	9	200	150

Esempio di ordinazione/Order example = A608-11-030-080 (codice)