

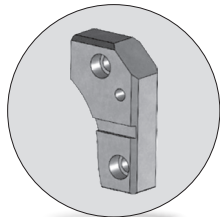

Camma di accelerazione *Acceleration cam*



Codice	Materiale
Cod. F3326	90MnCrV8 HRC 60 ÷ 62

OPEL code	R	w1	OPEL code	R	w1
F33260014	90	40°	F33260021	75	45°
F33260015	90	37,5°	F33260022	75	47,5°
F33260016	100	37,5°	F33260023	65	50°
F33260017	100	35°	F33260024	65	52,5°
F33260020	75	42,5°			

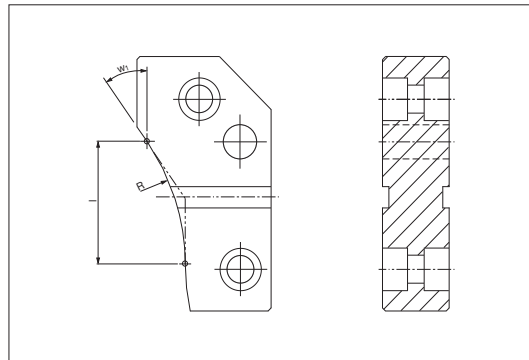

Esempio di ordinazione/Order example = F33260014 (OPEL code)