

# Portastampi per materie plastiche

Standard mold bases

## Materiale

1.1730 (C 45 W)

1.2738 (40 CrMnNiMo 8 6 4)

NOTA: si eseguono su richiesta portastampi speciali a disegno.

## Esecuzioni di serie

156	196	246	296	346	396	446	496	546	596
156	196	246	296	346	396	446	496	546	596
196	246	296	346	396	446	496	546	596	646
246	296	346	396	446	496	546	596	646	696
	346	396	446	496	546	596	646	696	746
							696	746	796
								796	

Sulle piastre PS e PF standard, sono stati aggiunti n° 4 filetti passanti M8, nei quattro angoli a: mm 10x10 = serie 156 e 196;

mm 12,5x12,5 = serie 246; mm 15x15 = serie 296 e 346;  
mm 17,5x17,5 = serie 396 e 446

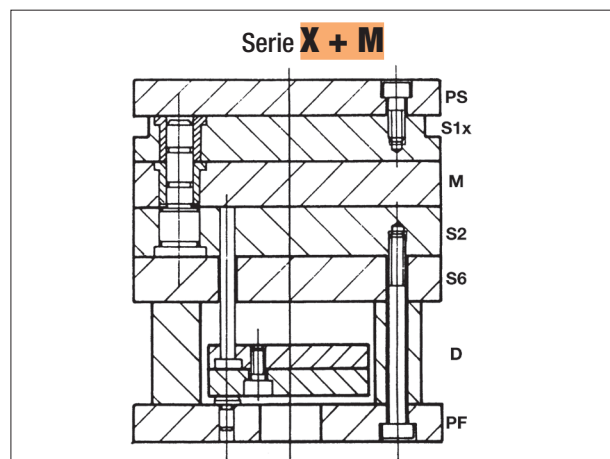
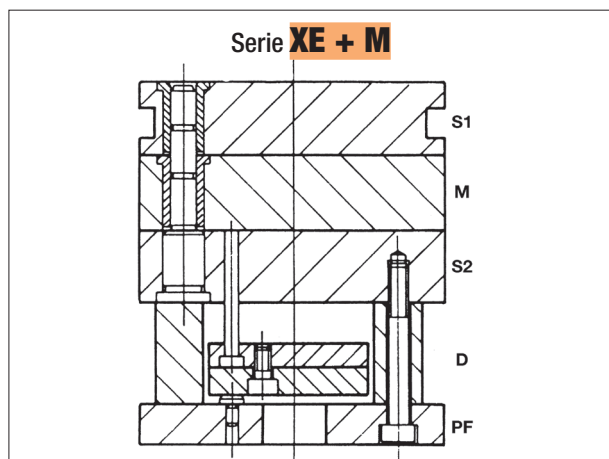
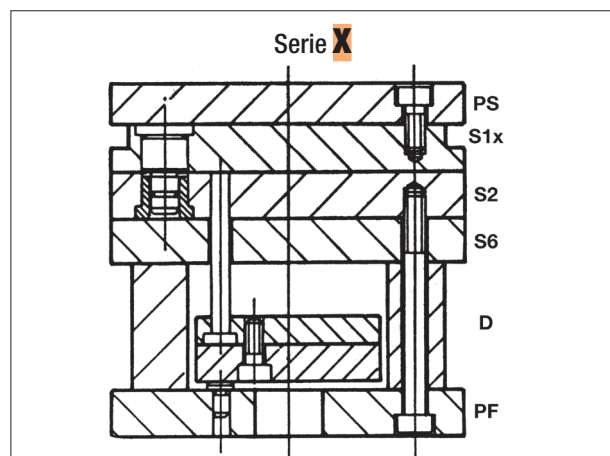
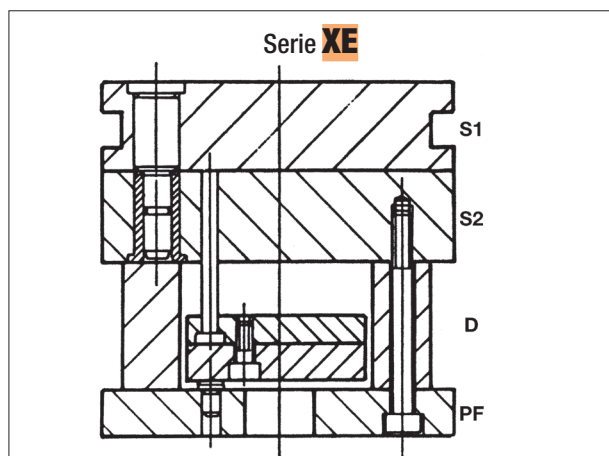

Su richiesta si esegue tavolino incolonnato.

